

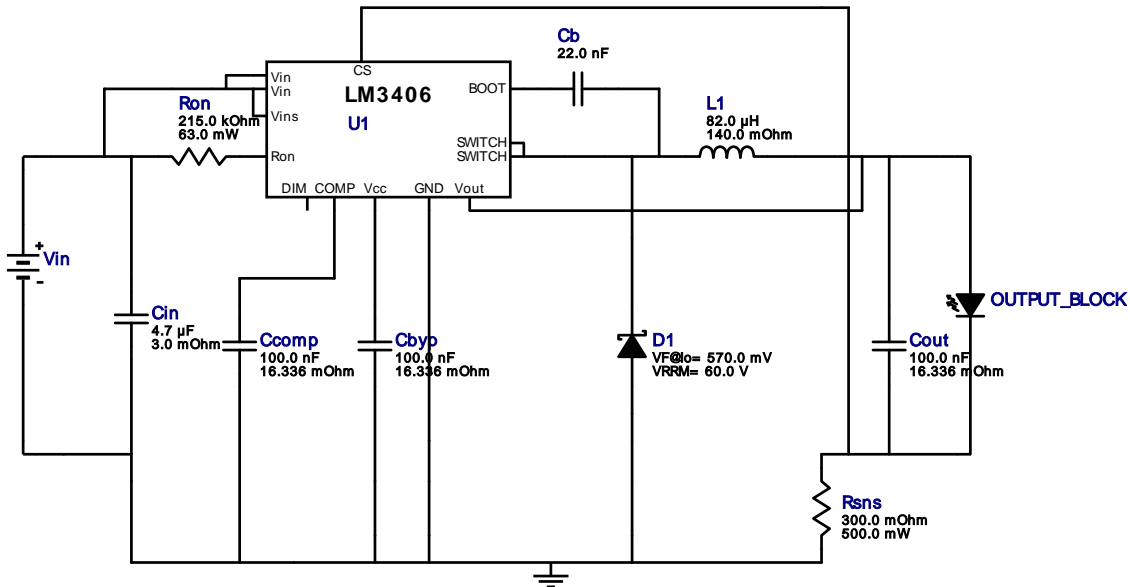











WEBENCH[®] Design Report

 Design : 4429012/9 LM3406MHX/NOPB
 LM3406MHX/NOPB 15.0V-30.0V to 11.70V @ 0.7A

 VinMin = 15.0V
 VinMax = 30.0V

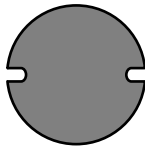
 Vout = 11.5V
 Iout = 0.7A

Electrical BOM

#	Name	Manufacturer	Part Number	Properties	Qty	Price	Footprint
1.	Cb	MuRata	GRM155R71E223KA61D Series= X7R	Cap= 22.0 nF VDC= 25.0 V IRMS= 0.0 A	1	\$0.01	 0402 3 mm ²
2.	Cbyp	TDK	C1608X7R1E104K Series= X7R	Cap= 100.0 nF ESR= 16.336 mOhm VDC= 25.0 V IRMS= 0.0 A	1	\$0.01	 0603 5 mm ²
3.	Ccomp	TDK	C1608X7R1E104K Series= X7R	Cap= 100.0 nF ESR= 16.336 mOhm VDC= 25.0 V IRMS= 0.0 A	1	\$0.01	 0603 5 mm ²
4.	Cin	MuRata	GRM31CR71H475KA12L Series= X7R	Cap= 4.7 uF ESR= 3.0 mOhm VDC= 50.0 V IRMS= 4.98 A	1	\$0.07	 1206 11 mm ²
5.	Cout	TDK	C1608X7R1H104K Series= X7R	Cap= 100.0 nF ESR= 16.336 mOhm VDC= 50.0 V IRMS= 0.0 A	1	\$0.01	 0603 5 mm ²
6.	D1	NXP Semiconductor	PMEG6010CEH,115	VF@Io= 570.0 mV VRRM= 60.0 V	1	\$0.11	 SOD-123F 12 mm ²
7.	D_LED	Cree	XHP50A-00-0000-0D00J40E1ED		1	\$6.54	 xlampxhp 0 mm ²

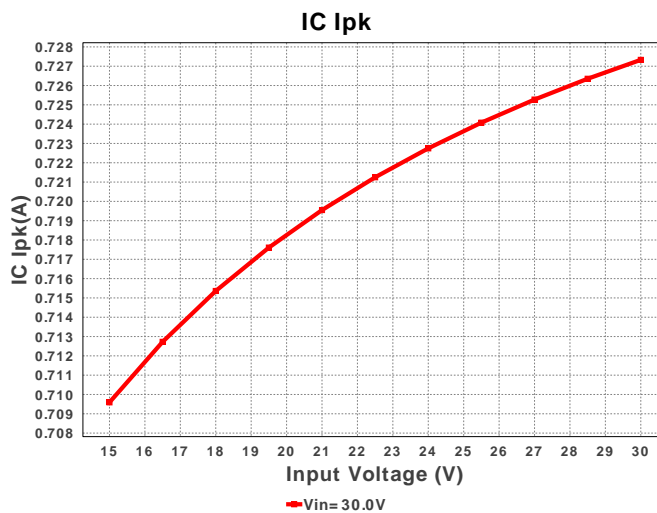
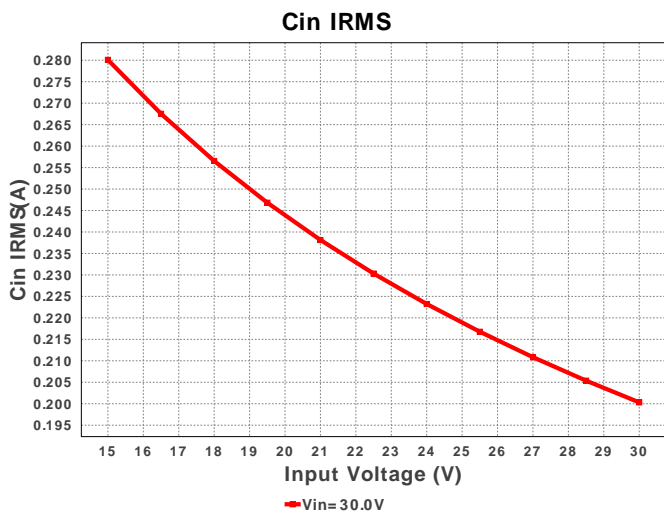
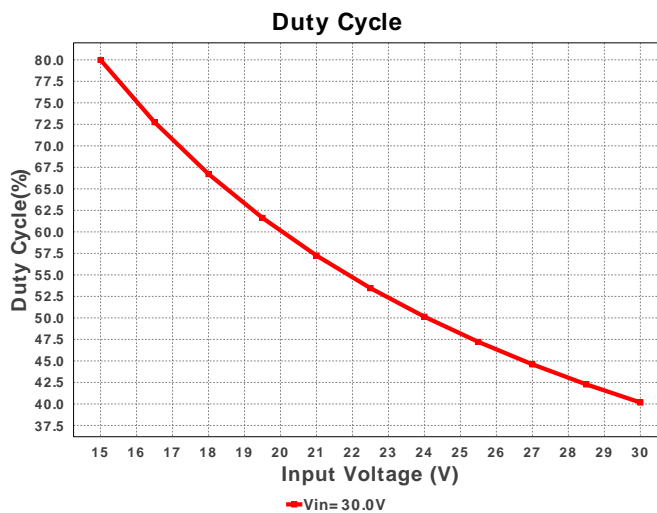
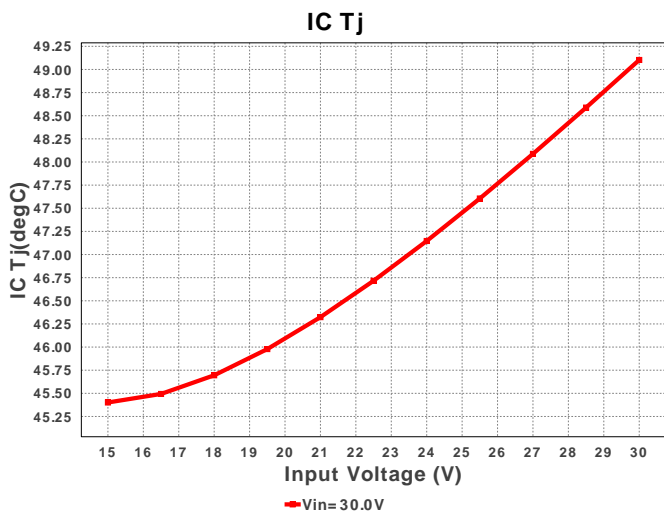
#	Name	Manufacturer	Part Number	Properties	Qty	Price	Footprint
8.	L1	Bourns	SDR1307-820KL	L= 82.0 μ H DCR= 140.0 mOhm	1	\$0.35	 SDR1307 227 mm ²
9.	Ron	Vishay-Dale	CRCW0402215KFKED Series= CRCW.e3	Res= 215.0 kOhm Power= 63.0 mW Tolerance= 1.0%	1	\$0.01	 0402 3 mm ²
10.	Rsns	Rohm	MCR25JZHFLR300 Series= MCR25	Res= 300.0 mOhm Power= 500.0 mW Tolerance= 1.0%	1	\$0.03	 1210 15 mm ²
11.	U1	Texas Instruments	LM3406MHX/NOPB	Switcher	1	\$0.95	 MXA14A 59 mm ²

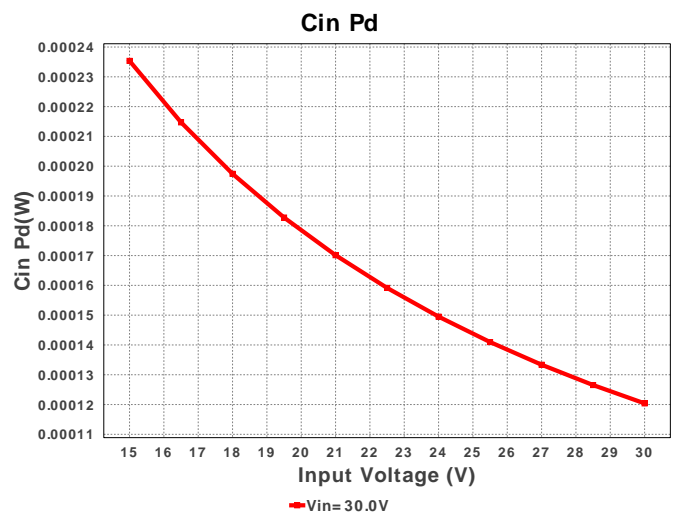
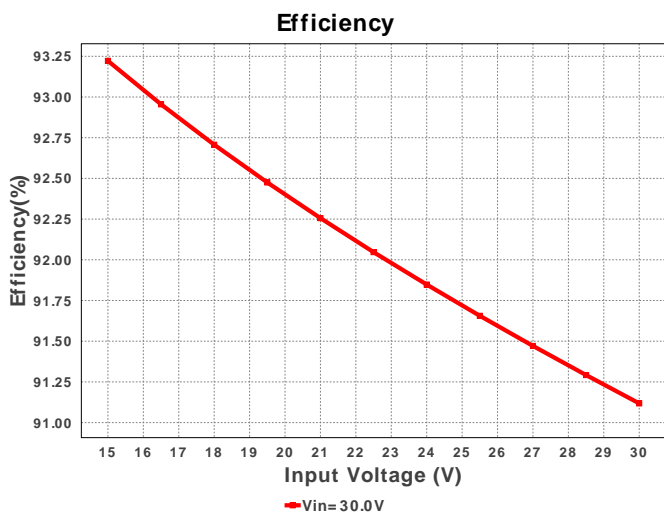
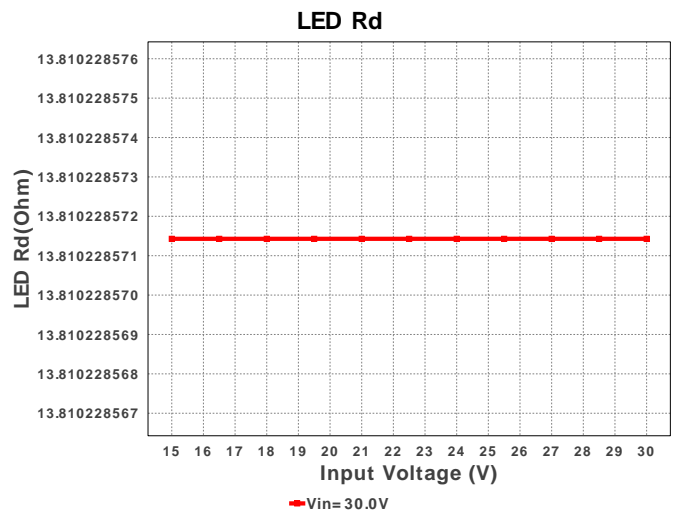
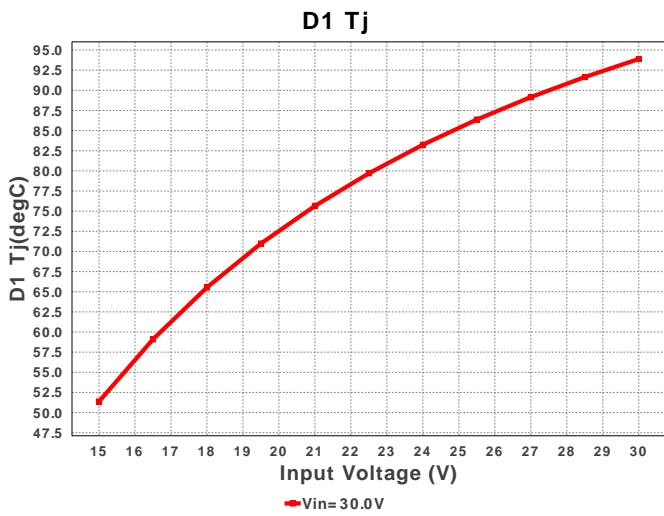
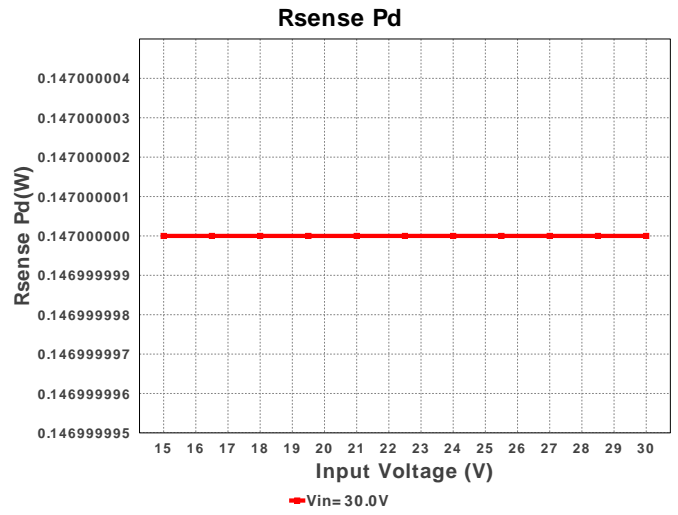
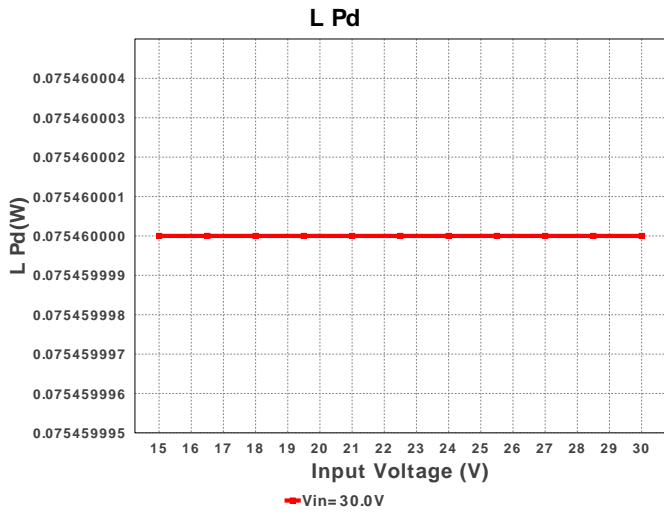

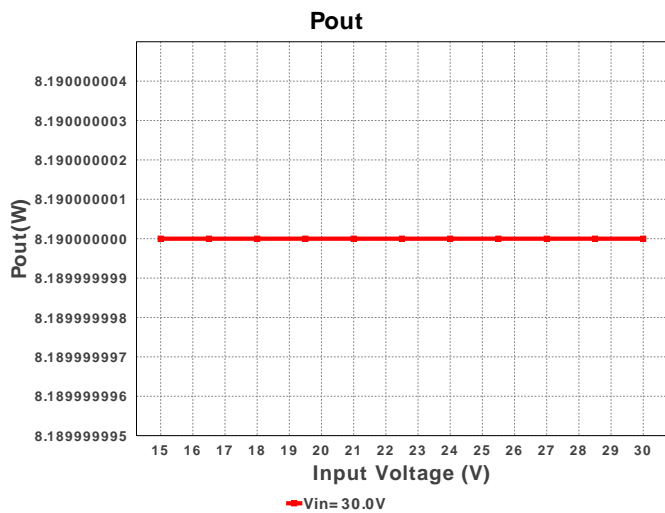
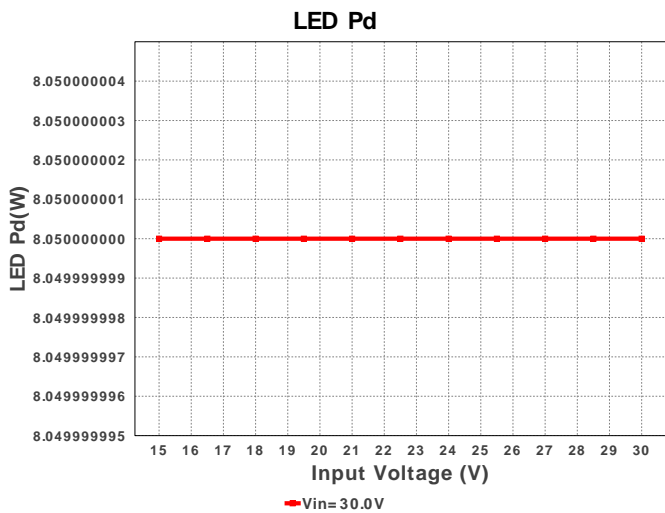
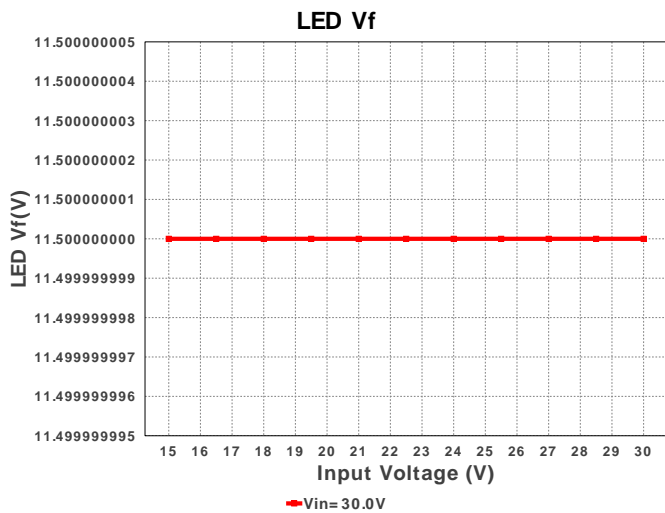
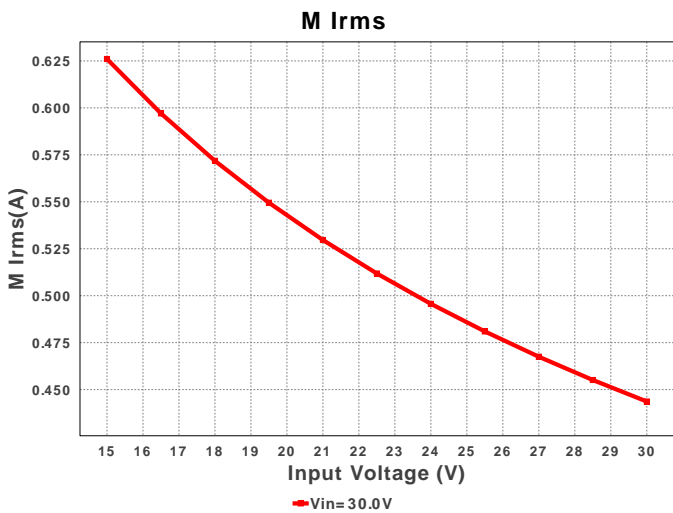
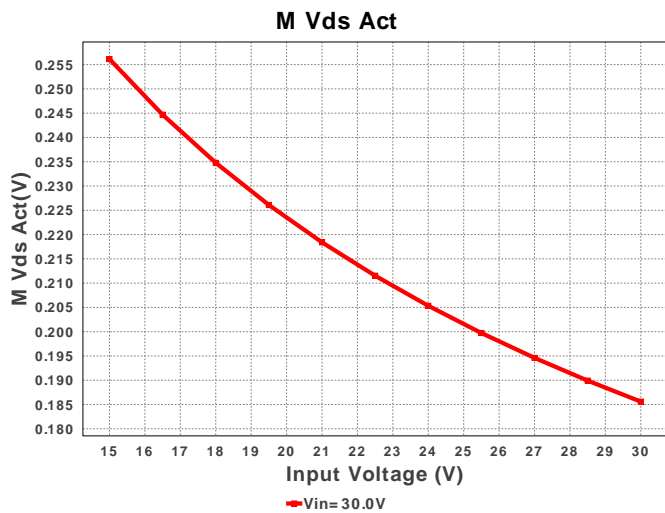
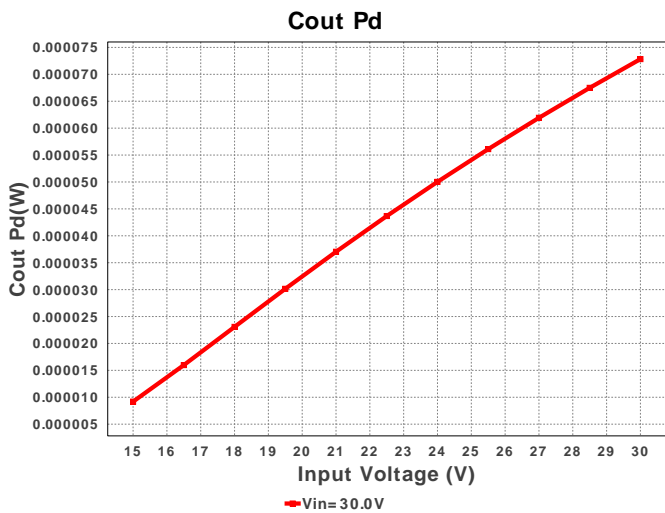



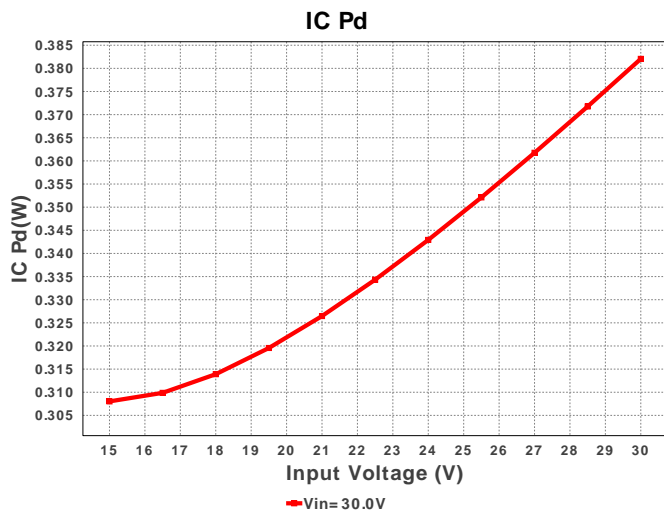
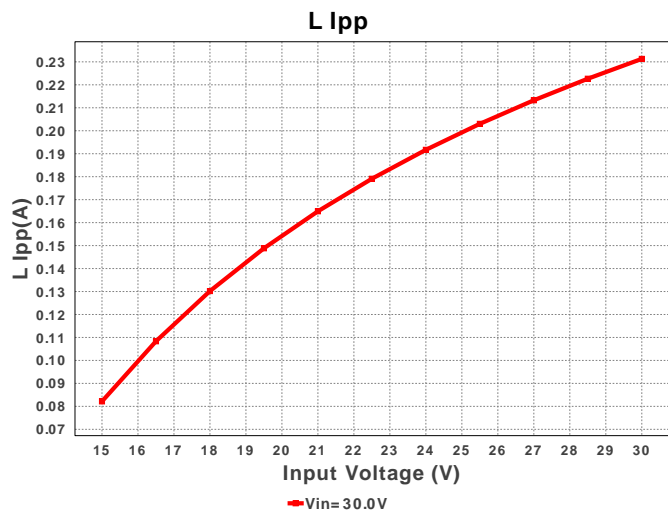
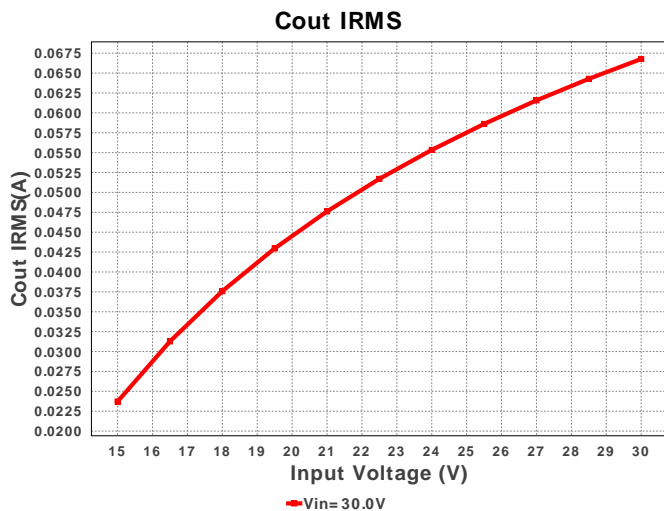
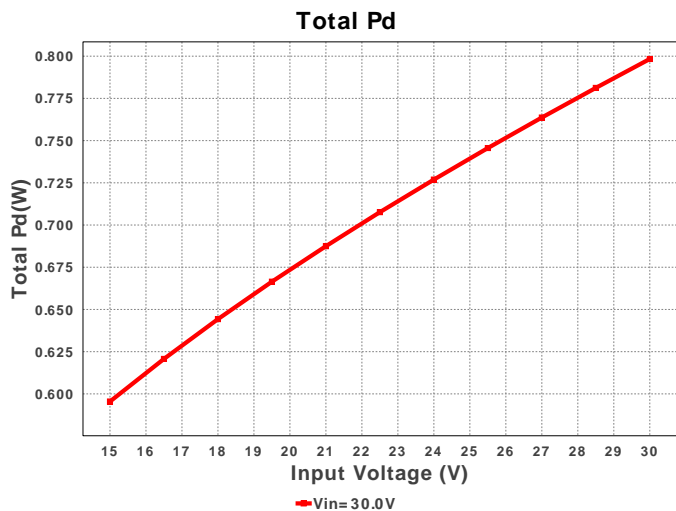
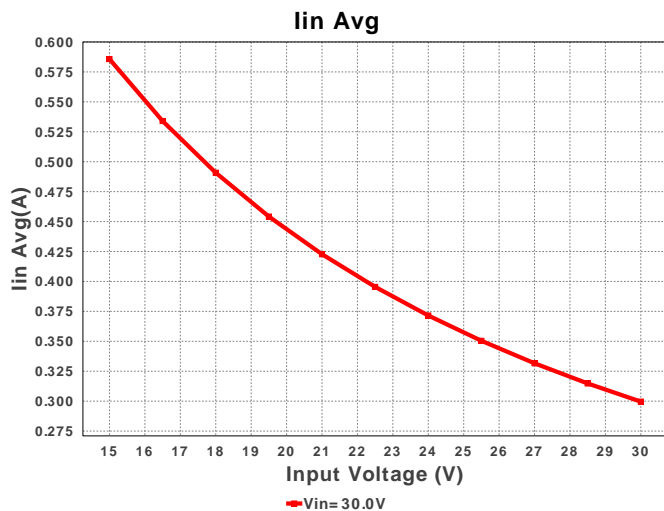
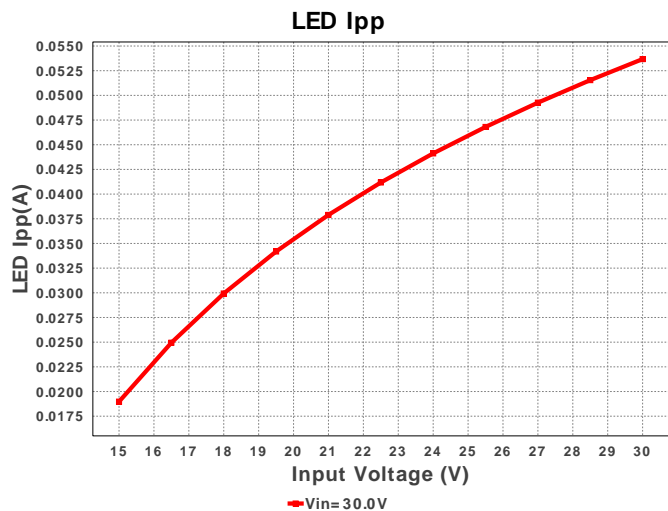

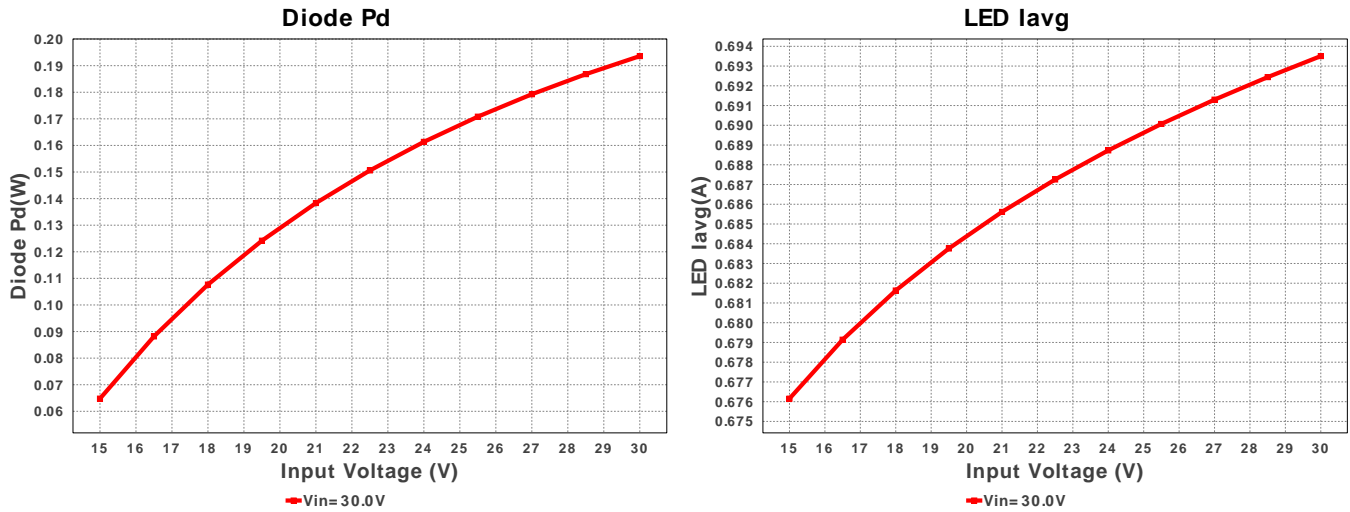

Operating Values

#	Name	Value	Category	Description
1.	Cin IRMS	200.384 mA	Current	Input capacitor RMS ripple current
2.	Cout IRMS	66.653 mA	Current	Output capacitor RMS ripple current
3.	IC Ipk	826.493 mA	Current	Peak switch current in IC
4.	Iin Avg	299.12 mA	Current	Average input current
5.	L Ipp	230.89 mA	Current	Peak-to-peak inductor ripple current
6.	LED Iavg	693.207 mA	Current	LED Average Current
7.	LED Ipp	53.08 mA	Current	LED Ripple Current
8.	M Irms	443.275 mA	Current	MOSFET RMS current
9.	BOM Count	11	General	Total Design BOM count
10.	FootPrint	343.0 mm ²	General	Total Foot Print Area of BOM components
11.	Frequency	387.592 kHz	General	Switching frequency
12.	IC Tolerance	10.0 mV	General	IC Feedback Tolerance
13.	M Vds Act	185.277 mV	General	Voltage drop across the MosFET
14.	Pout	8.19 W	General	Total output power
15.	Total BOM	\$8.1	General	Total BOM Cost
16.	D1 Tj	89.105 degC	Op_Point	D1 junction temperature
17.	Vout OP	11.7 V	Op_Point	Operational Output Voltage
18.	Duty Cycle	40.101 %	Op_point	Duty cycle
19.	Efficiency	91.267 %	Op_point	Steady state efficiency
20.	IC Tj	49.096 degC	Op_point	IC junction temperature
21.	ICThetaJA	50.0 degC/W	Op_point	IC junction-to-ambient thermal resistance
22.	IOUT_OP	700.0 mA	Op_point	Iout operating point
23.	LED Rd	13.81 Ohm	Op_point	LED DynamicResistance
24.	LED Vf	11.5 V	Op_point	Total LED Forward Calculated Voltage
25.	VIN_OP	30.0 V	Op_point	Vin operating point
26.	Cin Pd	120.462 μW	Power	Input capacitor power dissipation
27.	Cout Pd	72.575 μW	Power	Output capacitor power dissipation
28.	Diode Pd	179.106 mW	Power	Diode power dissipation
29.	IC Pd	381.911 mW	Power	IC power dissipation
30.	L Pd	75.46 mW	Power	Inductor power dissipation
31.	LED Pd	8.05 W	Power	LED Power Dissipation
32.	Rsense Pd	147.0 mW	Power	LED Power Dissipation
33.	Total Pd	783.664 mW	Power	Total Power Dissipation

Design Inputs

#	Name	Value	Description
1.	Iout	700.0 m	Maximum Output Current
2.	Iout1	700.0 m	Output Current #1
3.	VinMax	30.0	Maximum input voltage
4.	VinMin	15.0	Minimum input voltage
5.	Vout	11.5	Output Voltage
6.	Vout1	11.5	Output Voltage #1
7.	application	LED_DRIVER	LED Application
8.	base_pn	LM3406	Texas Instruments Base Part Number
9.	isLEDArchitect	N	LED Architect Project
10.	ledparallel	1.0	Number of LED in parallel
11.	ledpartnumber	XHP50A-00-0000-0D001	LED Part number
12.	ledseries	1.0	Number of LED in series
13.	line_fsw	60.0	AC Line Frequency
14.	source	DC	Input Source Type
15.	ta	30.0	Ambient temperature

Design Assistance

1. LM3406 Product Folder : <http://www.ti.com/product/LM3406> : contains the data sheet and other resources.

Texas Instruments' WEBENCH simulation tools attempt to recreate the performance of a substantially equivalent physical implementation of the design. Simulations are created using Texas Instruments' published specifications as well as the published specifications of other device manufacturers. While Texas Instruments does update this information periodically, this information may not be current at the time the simulation is built. Texas Instruments does not warrant the accuracy or completeness of the specifications or any information contained therein. Texas Instruments does not warrant that any designs or recommended parts will meet the specifications you entered, will be suitable for your application or fit for any particular purpose, or will operate as shown in the simulation in a physical implementation. Texas Instruments does not warrant that the designs are production worthy.

You should completely validate and test your design implementation to confirm the system functionality for your application prior to production.

Use of Texas Instruments' WEBENCH simulation tools is subject to [Texas Instruments' Site Terms and Conditions of Use](#). Prototype boards based on WEBENCH created designs are provided AS IS without warranty of any kind for evaluation and testing purposes and are subject to the terms of the [Evaluation License Agreement](#).